

## TDD-S

— unique, rear-mounted HVAC technology for double-decker applications —



# TDD-S

The Thermo King TDD-S unit is a multi-compartment air conditioning system designed for double deck buses. The TDD-S single piece evaporator, heater and condenser unit is rear mounted. The integrated unit ensures flawless bus aesthetics.

## CONTROLS

The Thermo King controls system is a CAN-based controller for bus air conditioning systems. The system is designed to control temperature in one, two, or three separate zones. It allows automatic or operator selected cool, heat and vent mode operation. Automatic and manual preheater control, driver defrost, and airflow controls are also available.

The CANAIRE system has several programmable features that provide flexibility in adapting the controller to many different heating and cooling applications. These controls operate on a 27V DC electrical source. It has a base module, optional display module, and up to four expansion modules. It has an RS232 interface for downloading data to a PC.

Different driver panels are available:

### CANAIRE



### ClimaAIRE



PERFORMANCE CHARACTERISTICS:		Rated	High Ambient
<b>Cooling Capacity - R134a model:</b>			
with X430 compressor		29 kW	36.0 kW
with S616 compressor		30 kW	41.0 kW
Refrigerant:		R134a	R134a
Ambient:		35 °C	42 °C
Interior dry Temp:		27 °C	49 °C
Interior wet Temp:		19 °C	26 °C
X430 Compressor RPM:		3000 1/min.	/
S616 Compressor RPM:		2000 1/min.	/
Refrigerant / Charge:		R134a	7,4 kg
<b>Max. operating temperature:</b>			
with capacity controlled compressor:		49 °C	
with fixed displacement compressor:		45 °C	
<b>Heating Capacity (system 1004 only):</b>		90 kW	
Coolant temp.inlet:		80 °C	
Return air temperature:		-20 °C	
Coolant flow:		16,7 L/min	
<b>Evap/Heater:</b>		Blower free blow: 10200 m <sup>3</sup> /h	
		Unit air flow: 7000 m <sup>3</sup> /h	
ELECTRICAL CHARACTERISTICS:			
<b>Voltage:</b>		27 V DC	
<b>Current (max.):</b>		Total:	186 A
		Unit:	174 A
		Boost pump:	8,5 A
		Comp. clutch:	3 A
PHYSICAL CHARACTERISTICS:			
<b>Weight</b>	Unit w/o compressor:	220 kg	
	Compressor X430 w/clutch	52 kg	
	Compressor S616 w/clutch	72 kg	
<b>Unit Dimension:</b>	Length	2140 mm	
	Height	1020 mm	
	Width	715 mm	

**Dimensions:** 2140 mm x 1020 mm x 715 mm

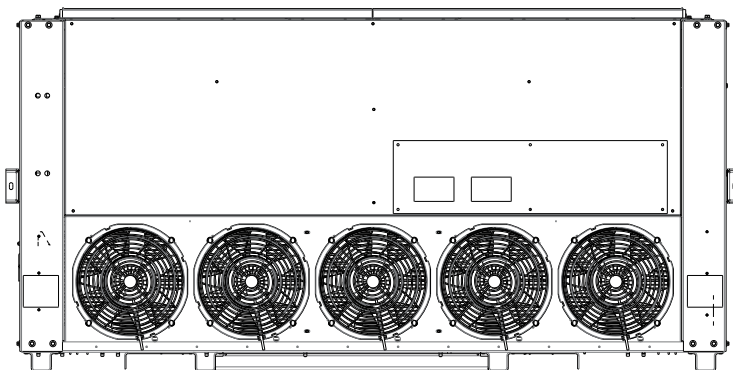

### Worldwide Service Organisation

Thermo King backs its equipment and customers with a highly trained, worldwide service organisation. This assures you the support of factory authorised service support and shop facilities, a stock of factory parts, and factory trained mechanics.

### Thermo King Europe

Kolin, Czech Republic  
Tel: + 420 321 757111  
Fax: + 420 321 757170

### Thermo King Americas

Minneapolis, MN U.S.A.  
Tel: + 1 952 887 2200  
Fax: + 1 952 887 2529

**MONZONE®**

**TRANE**  
TECHNOLOGIES

For further information, please contact:  
[europe.thermoking.com](http://europe.thermoking.com)

Find your nearest dealer on  
[dealers.thermoking.com](http://dealers.thermoking.com)

Thermo King Europe – Lenneke Marelaan 6, B-1932 Sint-Stevens-Woluwe, Belgium

© 2020 Thermo King Europe TK 80041 (08-2020)-EN